

MOUNTING INSTRUCTIONS

Stacking kit for washing machines and tumble dryers

DRAFT

Stacking kit for washing machines and tumble dryers

The creation of the stacking kit and in order to save space is available for all the front-loading washing machines which are 60 cm wide and have a depth which goes from 55 to 60 cm.

Procedure:

- Turn the tumble dryer on the right side making sure not to damage the cabinet
- Remove the front feet (fig. 1) and substitute them with the relative rubber feet (fig. 1a).

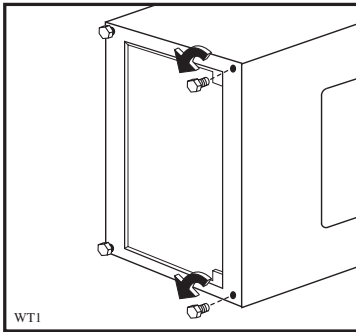

Fig 1

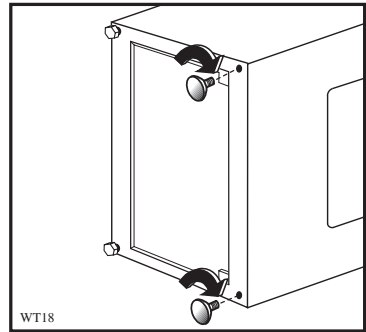

Fig 1a

- Place the tumble dryer on the top of the washing machine and unscrew the 2 screws, on the right and left side on the back of the tumble dryer.
- Place the relative metal fixing plates (fig. 2b/3b) and fix them with the included screws (A+B) both on the tumble dryer and on the upper corners.

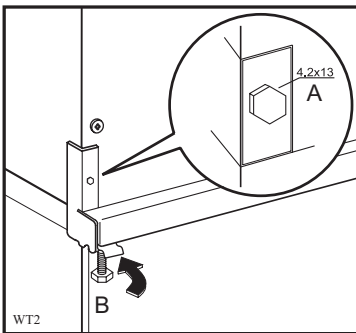

Fig 2 Small metal fixing plate

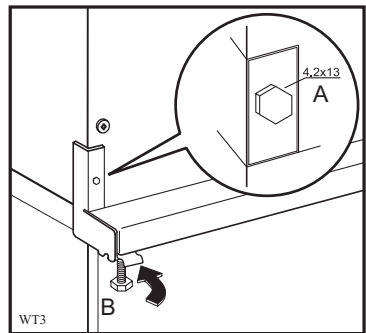

Fig 3 Large metal fixing plate

Screws A = self-tapping screws 4,2 x 13

Screws B = screw positioning

The figures below illustrate which metal plate according to the feet has to be used for the various washing machine and tumble dryer models.

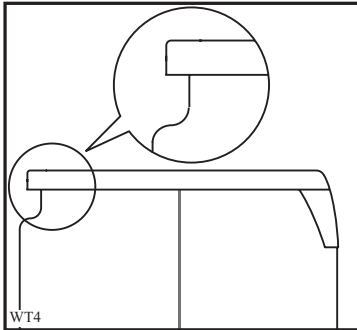

Fig 2a
Washing machines with top corner which protrudes a little.

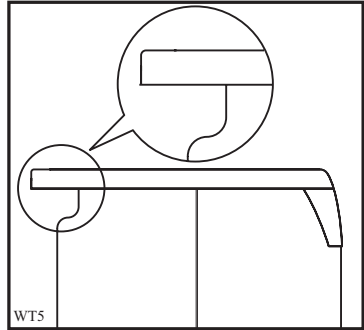

Fig 3a
Washing machines with top corner which protrudes a lot.

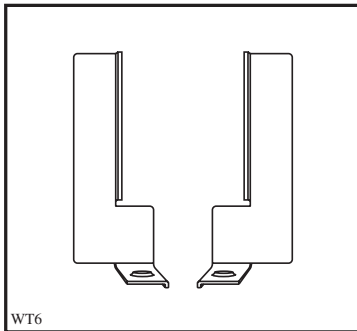

Fig 2b
Small metal fixing plate to be used on top corner washing machine which protrudes a little.

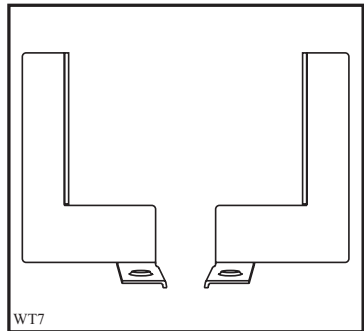

Fig 3b
Large metal fixing plate to be used on top corner washing machine which protrudes a lot.

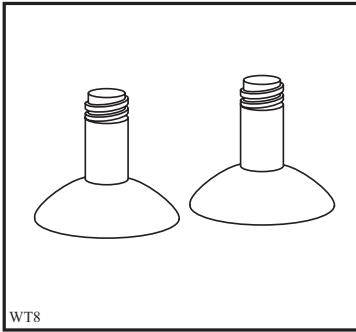

Fig 4

Long rubber feet (fig 4) to be used for the following tumble dryer models:

- Models without plinth (fig 5 and 6);
- Models with small door in plinth of the appliance (fig 7 and 8).

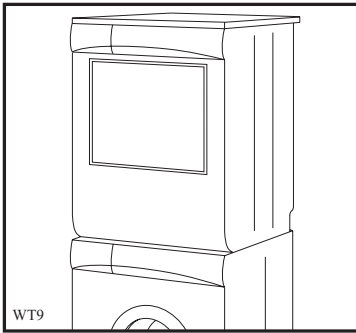

Fig 5

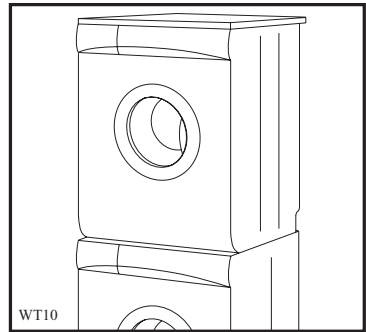

Fig 6

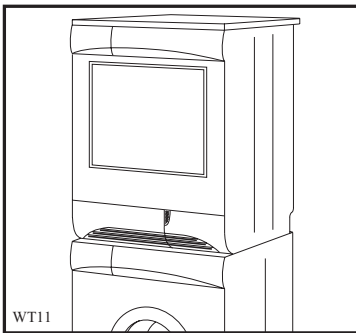

Fig 7

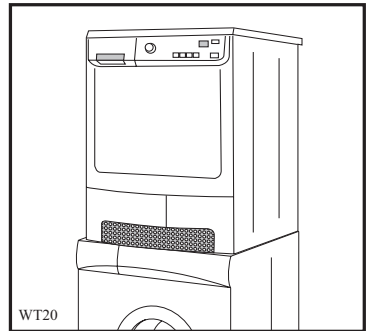

Fig 8

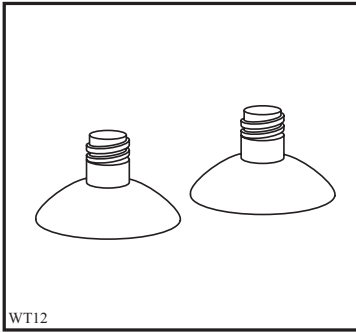

Fig 9

Short rubber feet (fig 9) to be used for the following tumble dryers models:

- Models with plinth (fig 10, 11, 12 and 13).

DRAFT

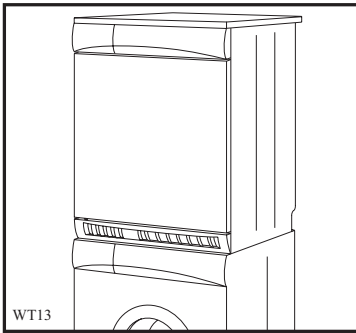

Fig 10

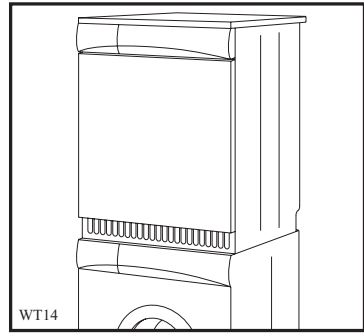

Fig 11

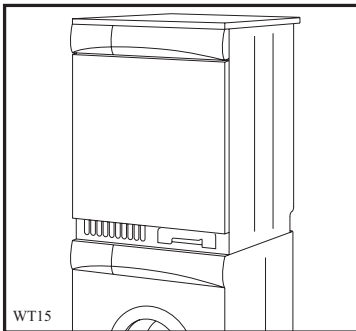

Fig 12

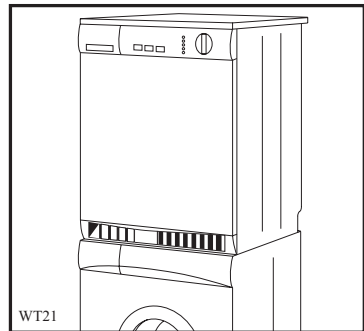
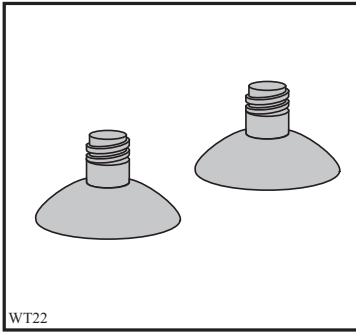

Fig 13



Grey short rubber feet (fig 14) to be used for the following tumble dryers models:

- Models with small door in plinth of the appliance (fig 15 and 16).

Fig 14

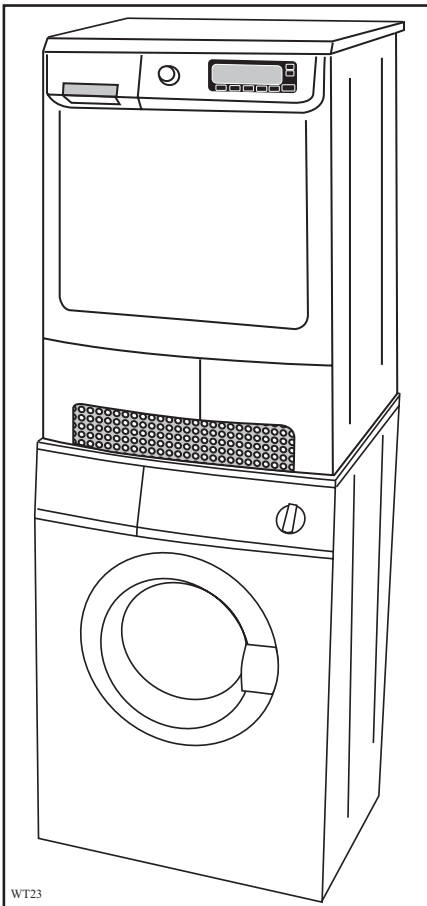

Fig 15

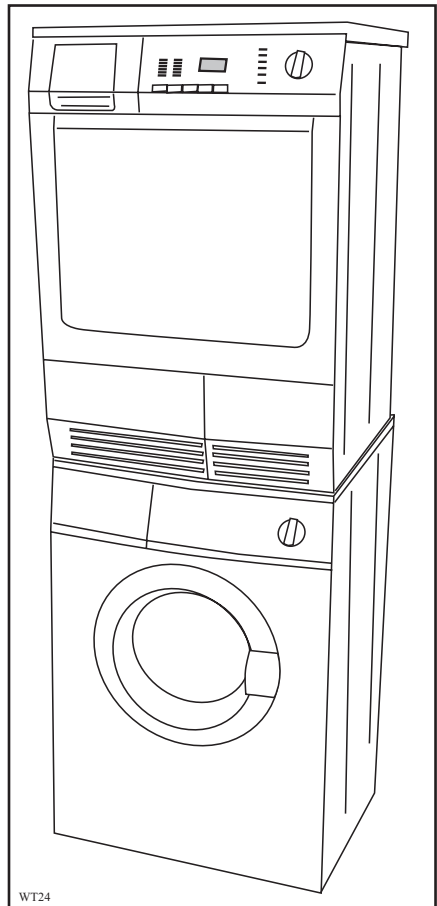

Fig 16